

JVC

SERVICE MANUAL

CASSETTE RECEIVER

KS-F161

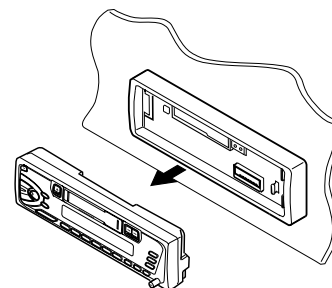
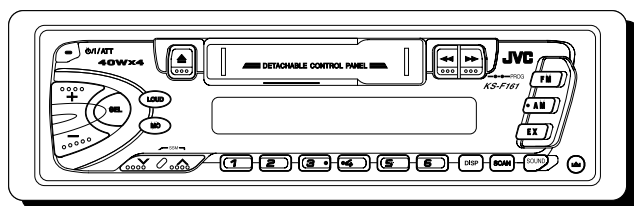

Area Suffix
U -----Other Areas

Contents

Safety precaution	1-2
Disassembly method	1-3
Adjustment method	1-12
Description of major ICs	1-16

Safety precaution

 **CAUTION** Burrs formed during molding may be left over on some parts of the chassis. Therefore, pay attention to such burrs in the case of performing repair of this system.

Disassembly method

■ Detaching the front panel unit

(See Fig.1)

Push the Release button in the direction of arrow to detach the front panel unit.

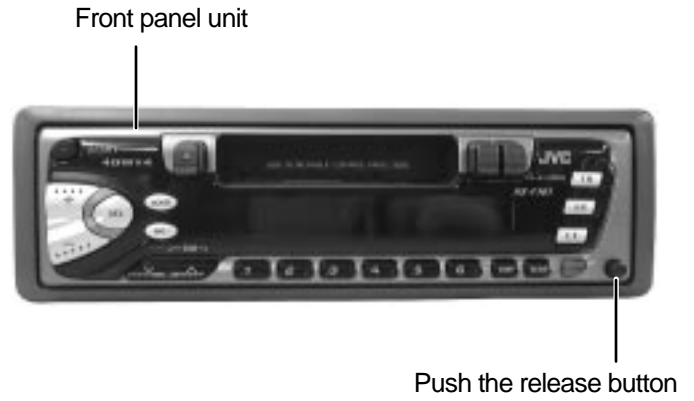

Fig. 1

■ Removing the front chassis

(See Fig. 2 and 3)

Disengage the four tabs (a) in the right and left sides of unit and pull the front chassis forward to remove it.

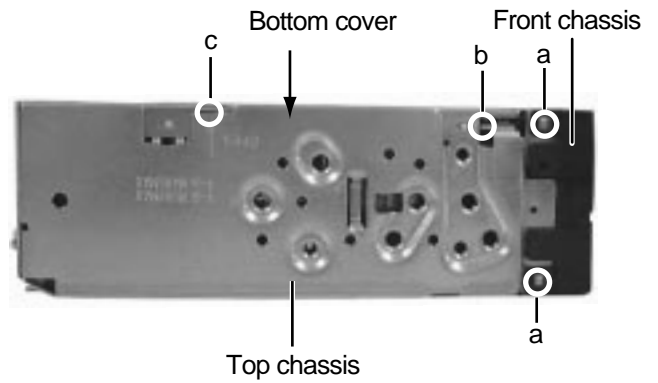

Fig. 2

■ Removing the bottom cover

(See Fig. 2 to 4)

1. Remove the front chassis.
2. Turn the unit up side down.
3. Insert the screwdriver to the four engagements (b, c, d, f).
4. Turn the screwdriver and remove the bottom cover.

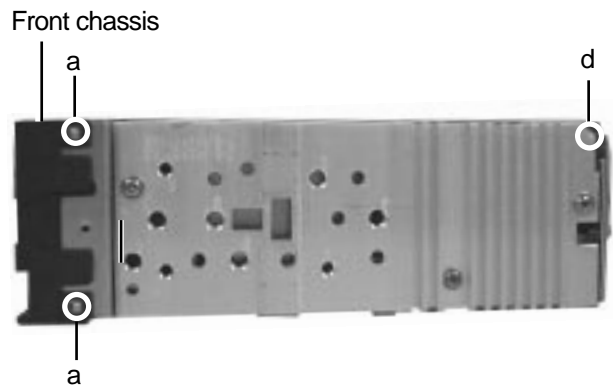

Fig. 3

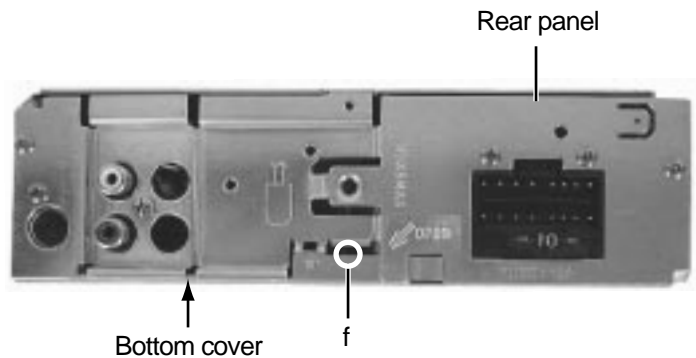

Fig. 4

■Removing the heat sink (SeeFig.5)

1. Removing the front chassis.
2. Removing the bottom cover.
3. Remove the three screws (1 and 1`) retaining the heat sink.

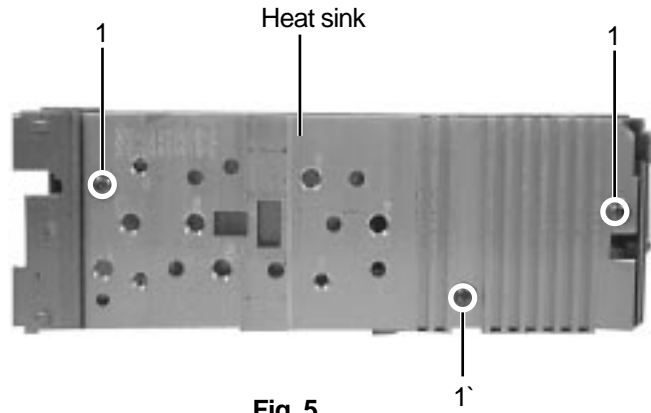

Fig. 5

■Removing the main board assembly

(See Fig. 5 to 7)

1. Removing the front chassis.
2. Removing the bottom cover.
3. Removing the heat sink.
 (Attach the heat sink with a screw (1`) on operating checks.)
4. Remove the two screws (2) retaining the main board assembly.
5. Remove the two screws (3) retaining the rear panel .
6. Separate the main board assembly and cassette mechanism assembly.
7. Take out the main board assembly.

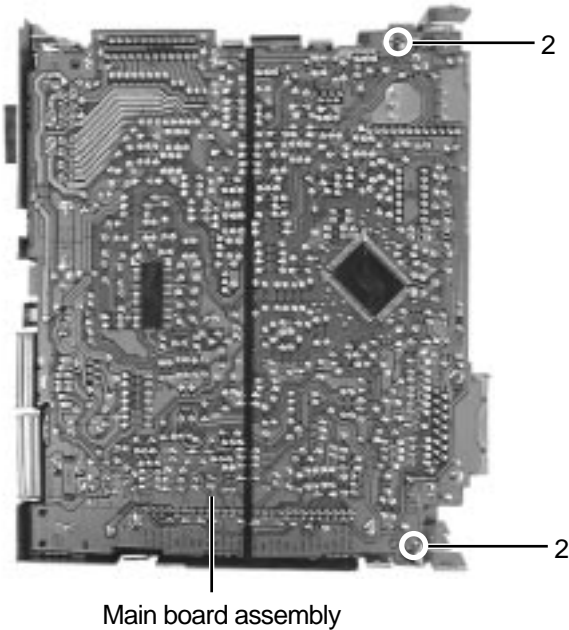

Fig. 6

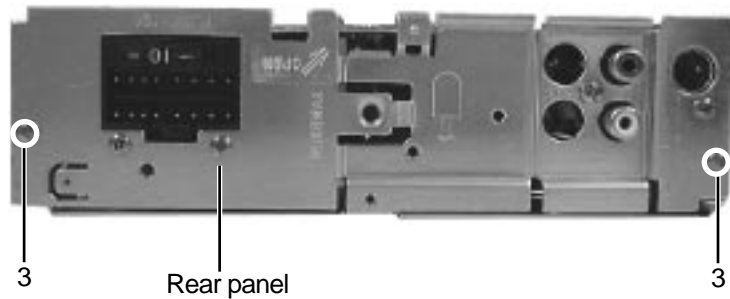

Fig. 7

■Removing the cassette mechanism assembly

(See Fig. 8)

1. Removing the front chassis.
2. Removing the bottom cover.
3. Removing the heat sink.
4. Removing the main board assembly.
5. Remove the four screws (4) retaining the cassette mechanism.
6. Separate the top chassis and cassette mechanism.

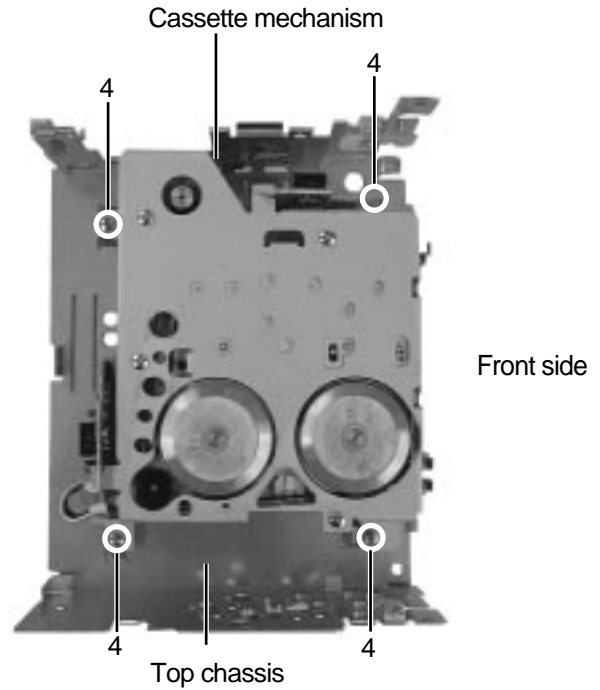

Fig. 8

■Removing the operation switch board

(See Fig. 9 to 11)

1. Detaching the front panel unit.
2. Turn the front panel back side down.
3. Remove the four screws (5) retaining the front cover.
4. Open the front cover gradually by disengaging the three engagements (g) while pushing the top of the front cover in the arrow "A" direction, then disengage the three engagements (h) on the both sides.
5. Place the front panel unit front side down.
6. Disengage the three engagements (i) on the bottom to separate the front cover from the front panel.

(Be careful not to lose the button springs.)

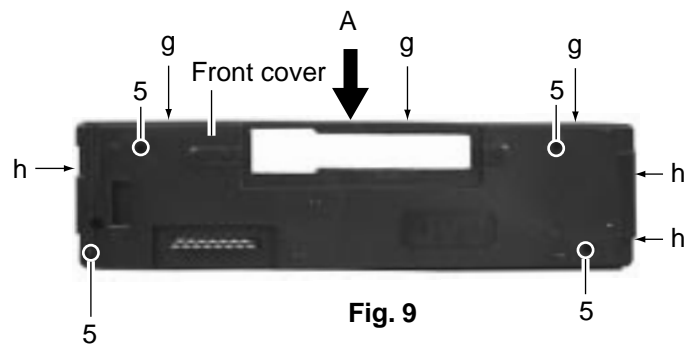

Fig. 9

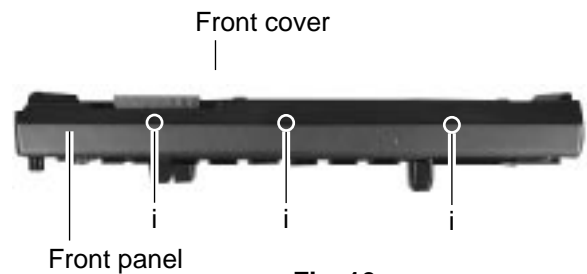

Fig. 10

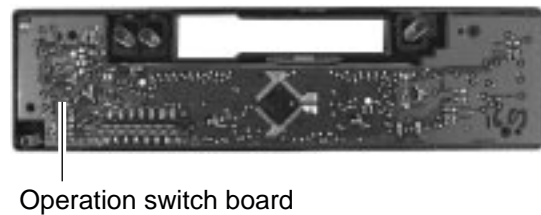

Fig. 11

■ Removing the head amplifier board

(See Fig. 12)

1. Removing the front chassis.
2. Removing the bottom cover.
3. Removing the heat sink.
4. Removing the main board assembly.
5. Removing the cassette mechanism.
6. Remove the screw (6) retaining the head amplifier board.
7. Shift the two inter rocking sections (j) securing the head amplifier board in the direction shown by the arrow "B" to remove the printed circuit board.
8. From the connector CJ901 on the head amplifier board from connector wire out going to the head relay board.

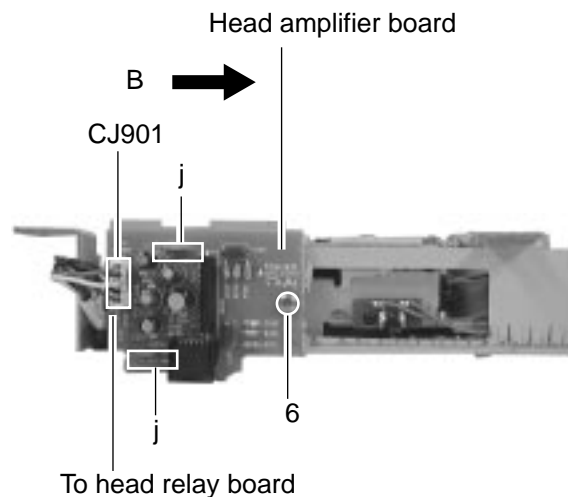

Fig. 12

■ Removing the chassis assembly

(See Fig. 13 and 14)

1. Removing the front chassis.
2. Removing the bottom cover.
3. Removing the heat sink.
4. Removing the main board assembly.
5. Removing the cassette mechanism.
6. Removing the head amplifier board.
7. Turn the left side to cassette mechanism.
8. Remove the screw (7) retaining the relay board.
9. Shift the one inter rocking sections (k) securing the relay board in the direction shown by the arrow "C" to remove the printed circuit board.
10. Turn the back side down, remove the four screws (8) retaining the chassis assembly.

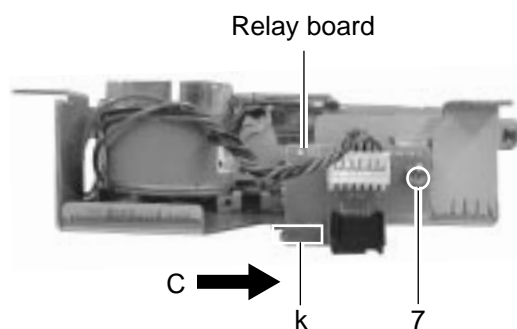

Fig. 13

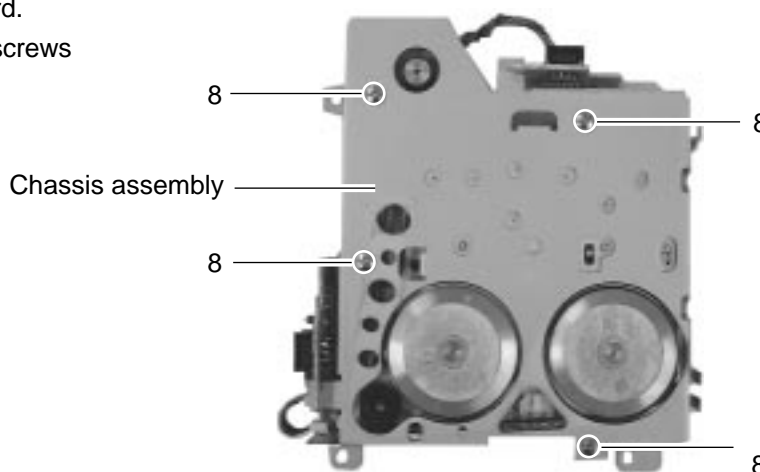

Fig. 14

<Cassette mechanism assembly>

- Prior to performing the following procedures, remove the head amplifier board, the relay board and the mechanism bracket.

■ Removing the direction switch board (See Fig.1)

1. Unsolder the three wires **a** on the direction switch board.
2. Remove the one screw **A** attaching the direction switch board.

■ Removing the FF / REW lever assembly (See Fig.1)

1. Remove the screw **B** attaching the FF / REW lever assembly on the back of the cassette mechanism assembly.
2. Remove the screw **C** on the upper side of the FF / REW lever assembly.
3. Lift and pull forward the FF / REW lever assembly to disengage the joints **b**, **c**, **d** and **e**.

■ Reattaching the FF / REW lever assembly (See Fig.1)

1. Reattach the FF / REW lever assembly to the joint **c** on the back of the chassis.
2. Reattach the pinch-roller shaft **e**, the change lever **d** and the return link **e** to the chassis.

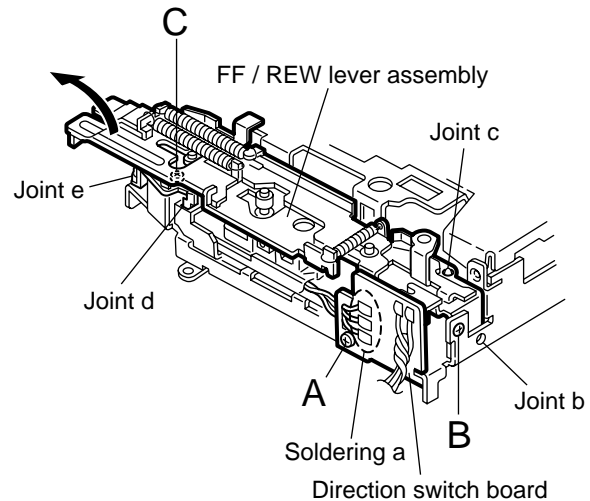

Fig.1

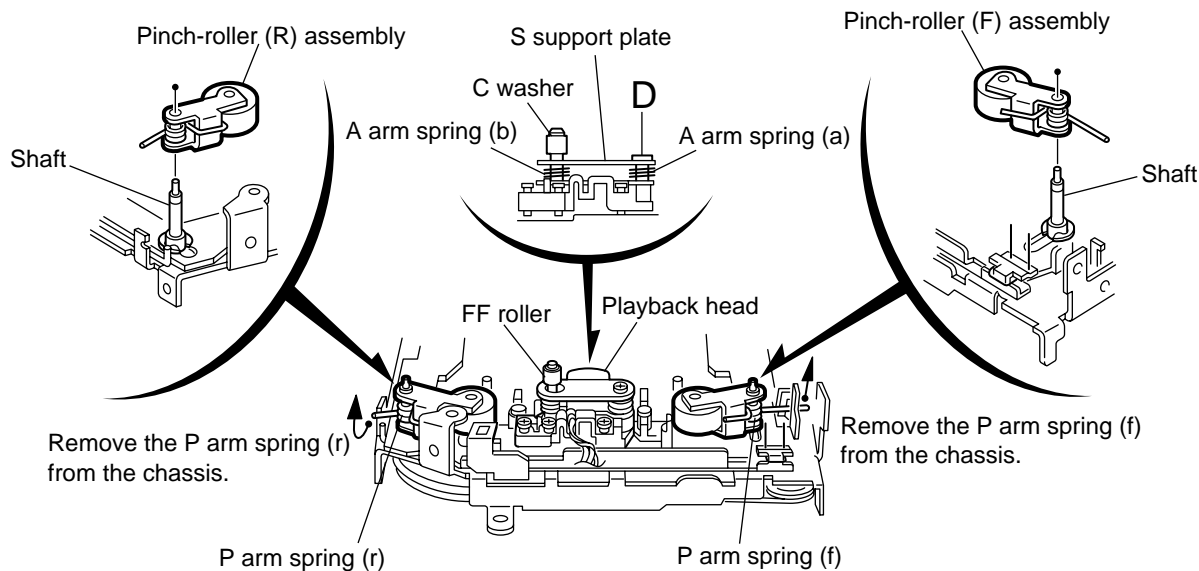

Fig.2

■ Removing the playback head (See Fig.2)

- Prior to performing the following procedure, remove the direction switch board and the FF / REW lever assembly.

1. Remove the screw **D** attaching the playback head.
2. Remove the **C** washer and pull out the FF roller.
3. Remove the **S** support plate, the **A** arm spring (a) and (b), the playback head.

ATTENTION: The **A** arm spring (a) differs from the **A** arm spring (b).

■ Removing the pinch-roller (R) and (F) assembly (See Fig.2)

- Prior to performing the following procedure, remove the direction switch board and the FF / REW lever assembly.

1. Remove the **P** arm spring (f) in the pinch-roller (F) assembly from the chassis.
2. Remove the **P** arm spring (r) in the pinch-roller (R) assembly from the chassis.
3. Draw out the pinch roller (F) and (R) assembly from the shaft.

ATTENTION: The **P** arm spring (f) differs from the **P** arm spring (r).

ATTENTION: The pinch roller (F) assembly differs from the pinch roller (R) assembly.

■ Removing the cassette hanger / cassette holder (See Fig.3)

• Prior to performing the following procedure, remove the FF / REW lever assembly.

1. From the rear of the unit, bend the two tabs **f** outwards and disengage the two joints **g** in the direction of the arrow.
2. Push the eject lever and remove the cassette holder from the playback head. Disengage the two joints **h** of the cassette hanger / cassette holder and the eject lever in the direction of the arrow.
3. Lift the cassette hanger / cassette holder and disengage the joint **i** of the return link and the eject lever.

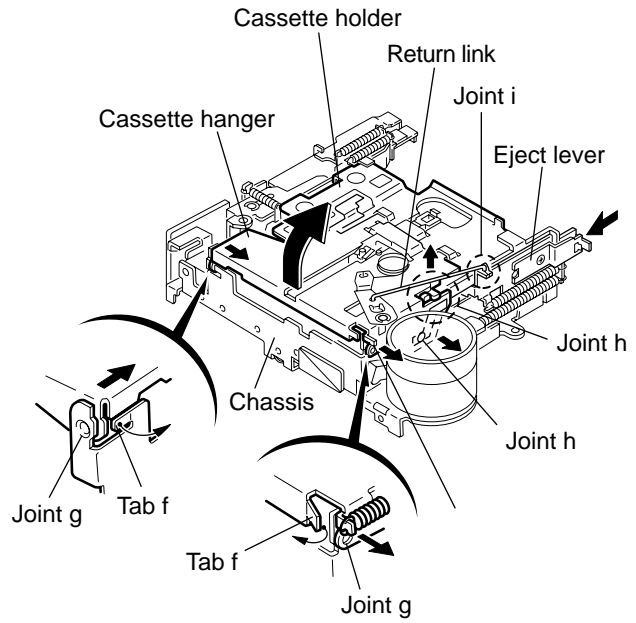

Fig.3

■ Removing the reel disc assembly (See Fig.4)

• Prior to performing the following procedure, remove the FF / REW lever assembly and the cassette hanger / cassette holder.

1. Remove the C washer and pull out reel disc assembly.

ATTENTION: Replace with a new C washer when reattaching.

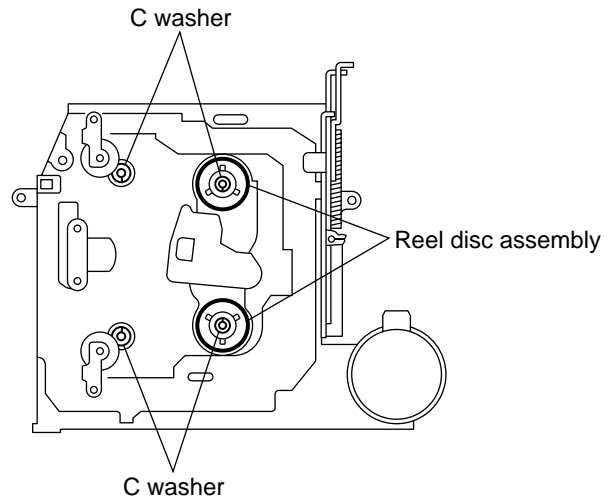

Fig.4

■ Removing the motor assembly (See Fig.5)

1. Unsolder the two wires **j** on the motor assembly.

ATTENTION: To replace the sub-belt, remove the main belt and the sub-belt from the motor pulley. Then remove the three screws **E** and one screw **F**. Replace with a new sub-belt while lifting the reel base assembly slightly.

2. Turn over the cassette mechanism assembly and remove the main belt and the sub-belt from the motor pulley.

ATTENTION: The main belt can now be removed.

3. Remove the two screws **G** attaching the motor assembly.

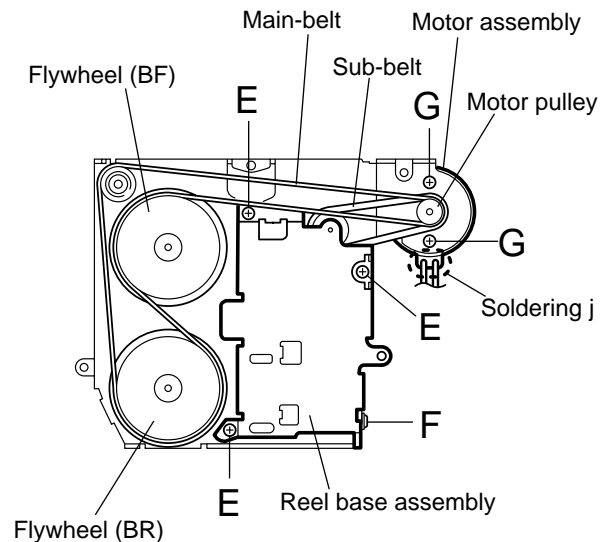

Fig.5

■ Removing the Flywheel (BF) and (BR) assembly (See Fig.4 and 5)

• Prior to performing the following procedure, remove the cassette hanger / cassette holder.

1. From the upper side of the cassette mechanism assembly, remove the C washer from each shaft of the flywheel (BF) and (BR).
2. Turn over the cassette mechanism assembly and remove the main belt. Pull out the flywheel (BF) and (BR) downward respectively.

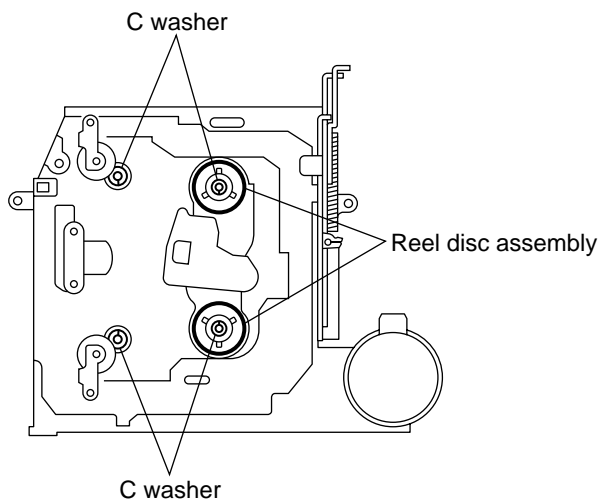

Fig.4

■ Removing the reel base assembly (See Fig.5 and 6)

1. Raise the part k of the reel base assembly slightly and remove the selector link (B) on the front side of the cassette mechanism assembly by turning it as shown in Fig.10.
2. Remove the three screws E and the one screw F on the underside of the cassette mechanism assembly.

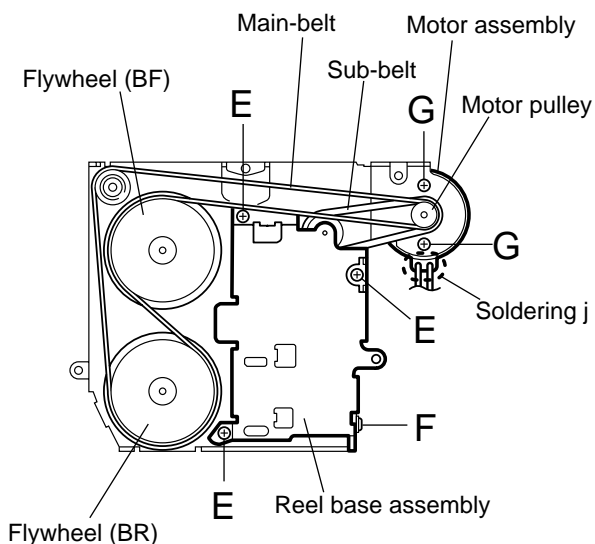

Fig.5

ATTENTION: The reel base assembly is not repairable. Handle with care.

Inside of the reel base assembly

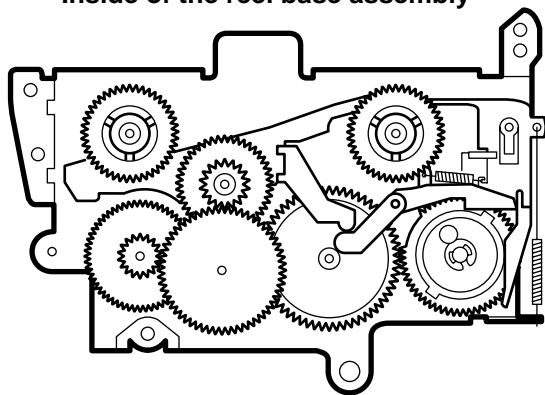

Fig.7

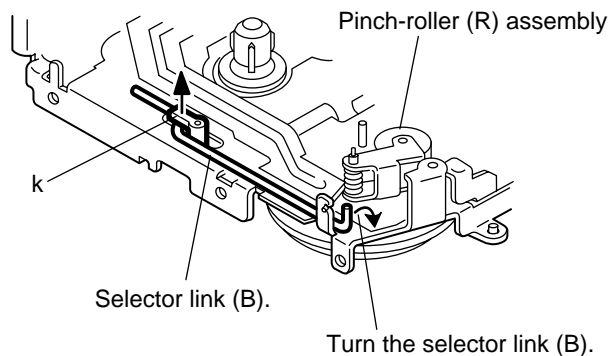

Fig.6

■ Removing the mute switch board

(See Fig.8)

1. Unsolder the two wires **I** on the mute switch board on the back of the cassette mechanism assembly.
2. Remove the screw **H** attaching the mute switch board.

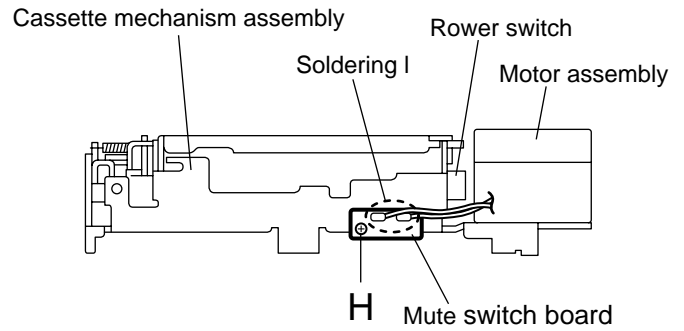

Fig.8

■ Removing the power switch (See Fig.9)

- Prior to performing the following procedure, remove the motor assembly.

1. Unsolder the two wires **m** on the power switch on the side of the cassette mechanism assembly.
2. Remove the screw **I** attaching the power switch.

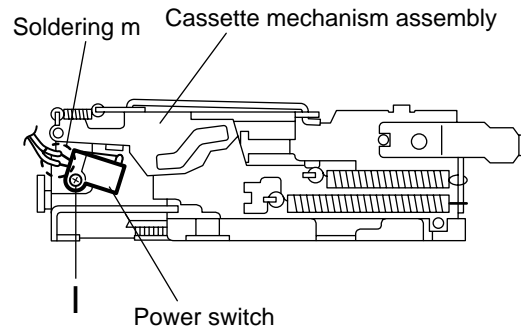

Fig.9

Adjustment method

■ Test instruments required for adjustment

1. Digital oscilloscope(100MHz)
2. Frequency counter meter
3. Electric voltmeter
4. Wow & flutter meter
5. Test tapes
 - VT724.....for DOLBY level measurement
 - VT739.....For playback frequency measurement
 - VT712....For wow flutter & tape speed measurement
 - VT703.....For head azimuth measurement
6. Torque gauge.....Cassette type for CTG-N
(Mechanism adjustment)

■ Standard volume position

Balance and Bass, Treble volume, Fader
:Center(Indication"0")
Loudness,Dolby NR,Sound,Cruise:Off
Volume position is about 2V at speaker output with
following conditions,Playback the test tape VT721.

- | | |
|----------------|--|
| AM mode | 999kHz/62dB,INT/400Hz,30%
modulation signal on receiving. |
| FM mono mode | 97.9MHz/66dB,INT/400Hz,22.5kHz
deviation pilot off mono |
| FM stereo mode | 1kHz,67.5kHz dev.pilot 7.5kHz dev |
| Output level | 0dB(1 μ V,50 Ω /open terminal) |

■ Measuring conditions(Amplifier section)

- Power supply voltage..... DC14.4V(11V - 16V allowance)
- Load impedance..... 4 Ω (4 Ω to 8 Ω allowance)
- Line out level/Impedance.....1.0V/20k Ω load (250 nWb/m)

■ Frequency band

Band	FM: 87.5 MHz to 108.0 MHz
	AM: 531 kHz to 1 602 kHz

■ Information for using a car audio service jig

1. For 1995 and 1996 , we're advancing efforts to make our extension cords common for all car audio products. Please use this type of extension cord as follows.
2. As a U-shape type top cover is employed, this type of extension cord is needed to check operation of the mechanism assembly after disassembly.
3. Extension cord : EXTKSRT002-6P (6 pin extension cord) For connection between mechanism assembly and main board assembly.
Check for mechanism driving section such as motor ,etc..

■ Disassembly method

1. Remove the bottom cover.
2. Remove the front panel assembly.
3. Remove the top cover .
4. Install the front panel.
5. Confirm that current is being carried by connecting an extension cord jig.

Note

Available to connect to the CN701 connector when installing the front panel.

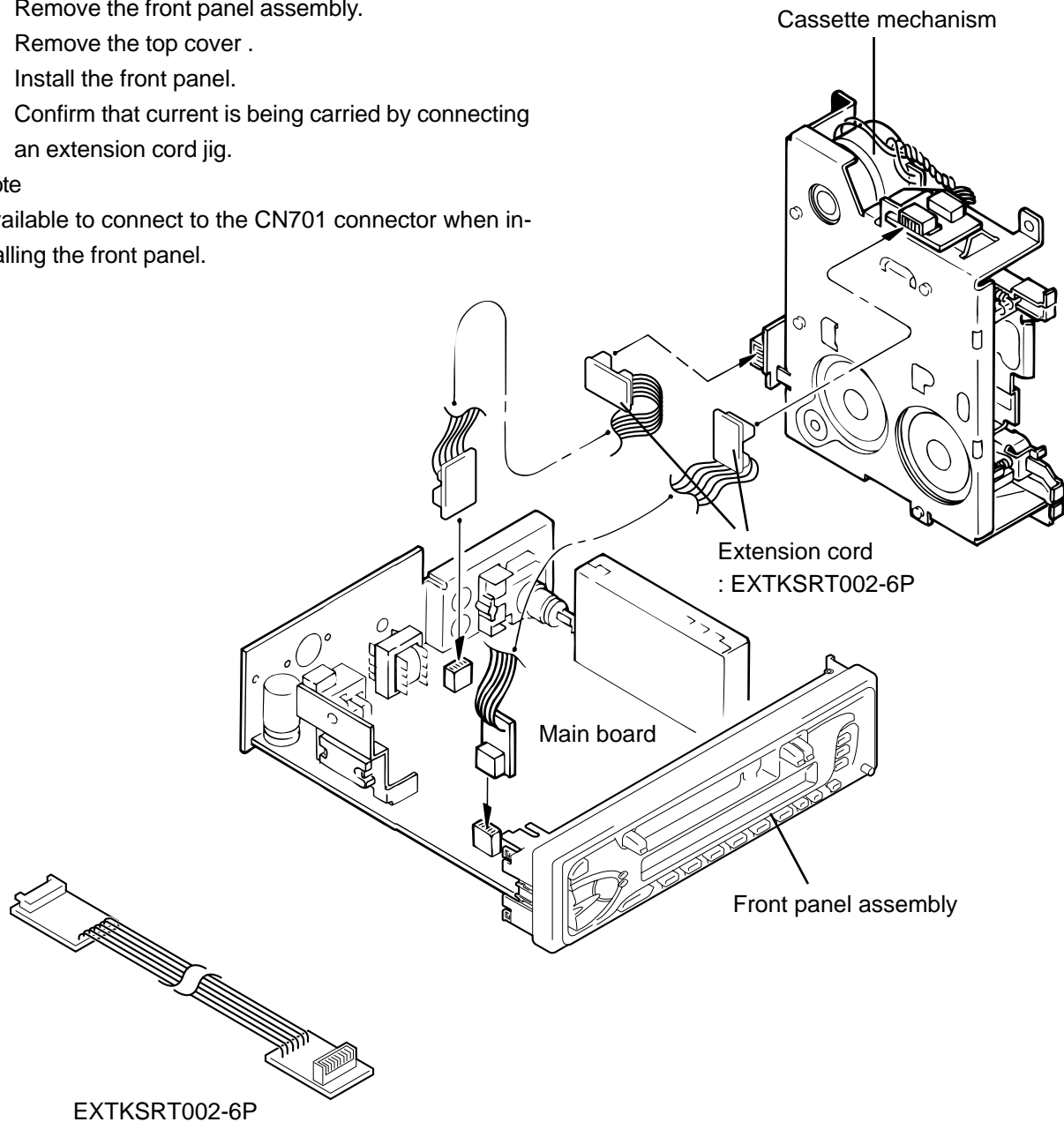

■ Arrangement of adjusting & test points

Cassette mechanism
(Surface)

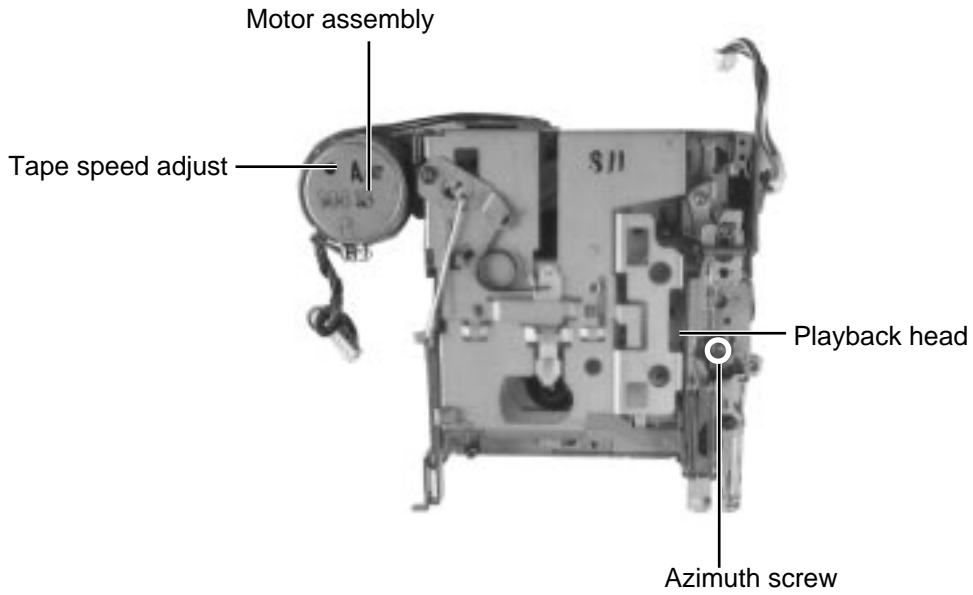

Head section view

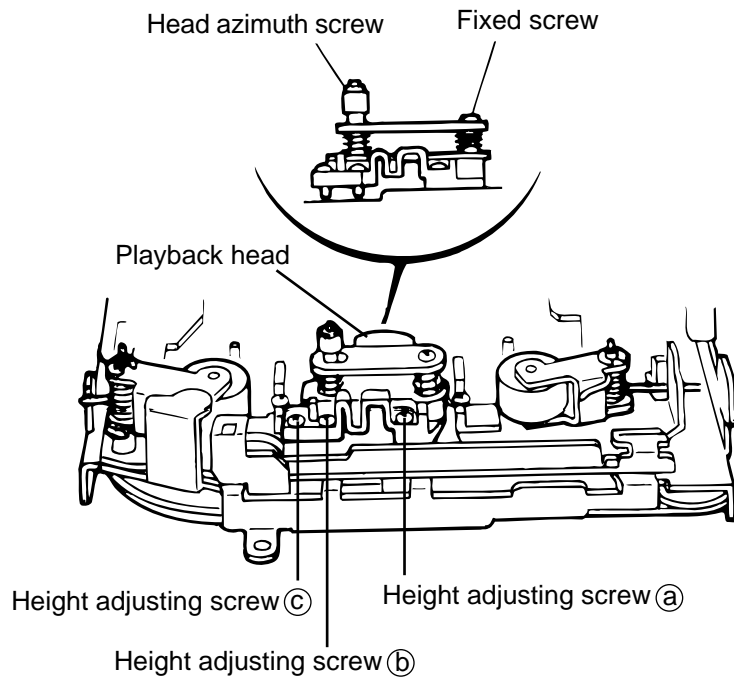

■ Mechanism adjustment section

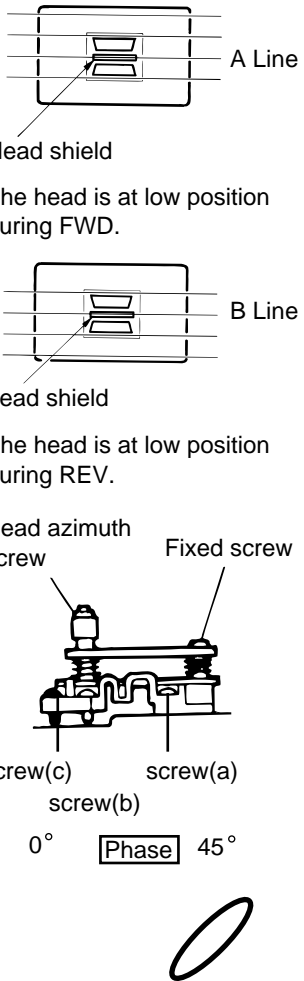
Item	Adjusting & Confirmation Methods	Adjust	Std.Value
<p>1.Head azimuth</p>	<p>"Head Height Adjustment"</p> <p>Note Adjust the azimuth directly. When you adjust the height using a mirror tape, remove the cassette housing from the mechanism chassis. After installing the cassette housing, perform the azimuth adjustment.</p> <ol style="list-style-type: none"> 1. Load the mirror tape (SCC-1659). Adjust with height adjustment screw(a) and azimuth adjustment screw(b) so that the "A" of the mirror tape runs in the center between Lch and Rch in the reverse play mode. 2. After switching from REV to FWD then to REV, check that the head position set in procedure "1" is not changed. *If the position has shifted, adjust again and check. 3. Adjust the azimuth screw (b) so that line "B" of the mirror tape runs in the center between Lch and Rch in the forward play mode. <p>"Head azimuth adjustment"</p> <ol style="list-style-type: none"> 1. Load the test tape (VT724: 1kHz) and play it back in the reverse play mode. set the Rch output level to maximum. 2. Load the test tape (VT703:10kHz) and play it back in the forward play mode. Adjust the Rch and Lch output levels to maximum, with azimuth adjustment screw(b). In this case, the phase difference should be within 45°. 3. Engage the reverse mode and adjust the output level to maximum, with azimuth adjustment screw (c). *The phase difference should be 45_Kor more. 4. When switching between forward and reverse modes, the difference between channels should be within 3dB. *Between FWD Lch and Rch REV Lcj and Rch. 5. When the test tape (VT721 : 315Hz) is played back, the level difference between channels should be within 1.5dB. 	<p>Adjust</p>  <p>Head shield</p> <p>The head is at low position during FWD.</p> <p>Head shield</p> <p>The head is at low position during REV.</p> <p>Head azimuth screw</p> <p>Fixed screw</p> <p>screw(c) screw(a) screw(b)</p> <p>0° Phase 45°</p>	<p>Std.Value</p>
<p>2.Tape speed and Wow & Flutter</p>	<ol style="list-style-type: none"> 1. Check to see if the reading of the frequency counter & Wow flutter meter is within 2940-3090 Hz(FWD/REV), and less than 0.35% (JIS RMS). 2. In case of out of specification, adjust the motor with a built-in volume resistor. 	<p>Built-in volume resistor</p>	<p>Tape speed 2940-3090Hz Wow & Flutter Less than 0.35% (JIS RMS)</p>
<p>3.Playback Frequency response</p>	<ol style="list-style-type: none"> 1. Play the test tape (VT724 : 1kHz) back and set the volume position at 2V. 2. Play the test tape (VT739)back and confirm 0 ± 3dB at 1kHz/8kHz and -4+2dB at 1kHz/125Hz. 3. When 8kHz is out of specification, it will be necessary to read adjust the azimuth. 		<p>Speaker out 1kHz/8kHz : 0dB }3dB, 125Hz/1kHz : -4dB+2dB,</p>

Description of major ICs

■ AN80T05LF (IC781) : Regulator

1. Terminal layout & Block diagram

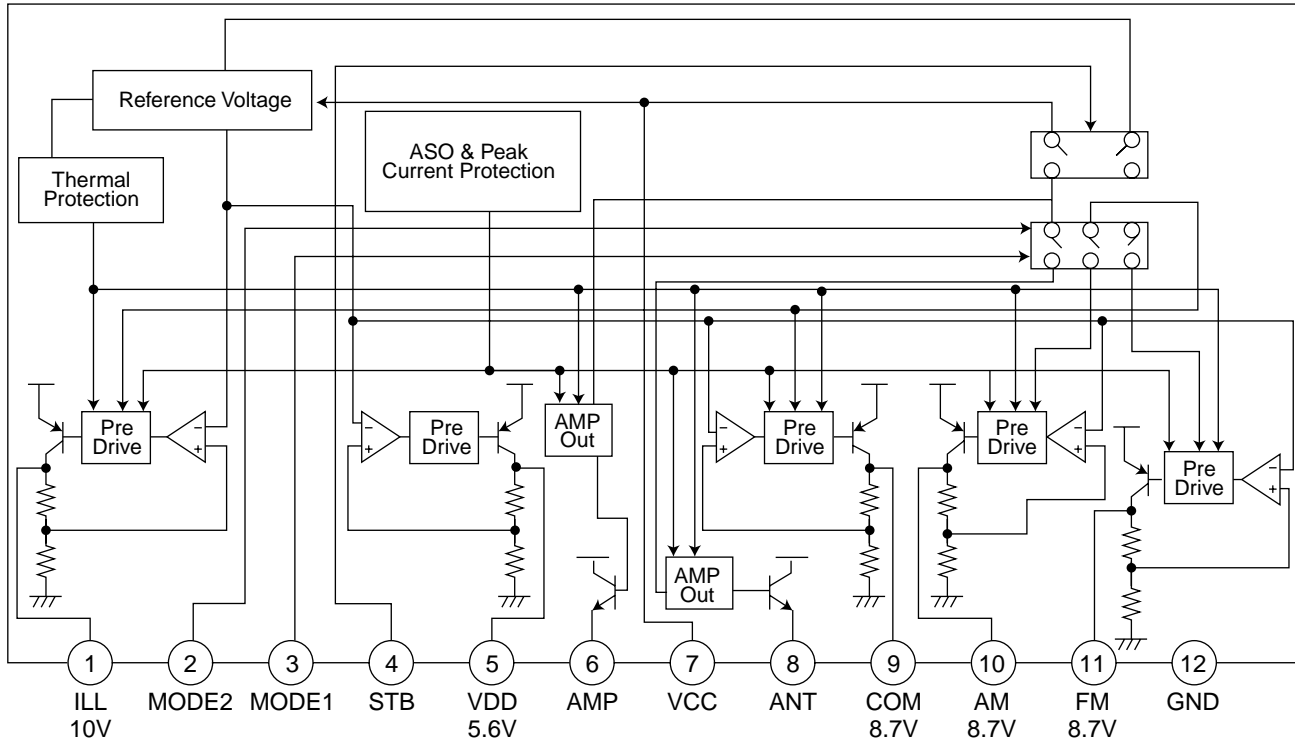

2. Pin function

Pin No.	Symbol	Function
1	NC	Non connect
2	TUNER	When 5V is input, becomes AM. and the antenna output is turned on.
3	FM/AM	When 5V is input, becomes AM. and the output of FM is switched.
4	POWER CNT	When 5V is input, outputs to ILL, COM, and AMP. It is 0V usually.
5	5V	5.6V power supply.
6	VSW 14VOUT	Power supply supply to remote amplifier
7	MEMORY	Back up. connects with ACC with it.
8	NC	Non connect
9	9V	8.7V power supply.
10	AM	The power supply of 8.7V to AM.
11	FM	The power supply of 8.7V to FM.
12	GND	Ground

■ LC75823W (IC651) : LCD driver

1. Pin Layout & Symbol

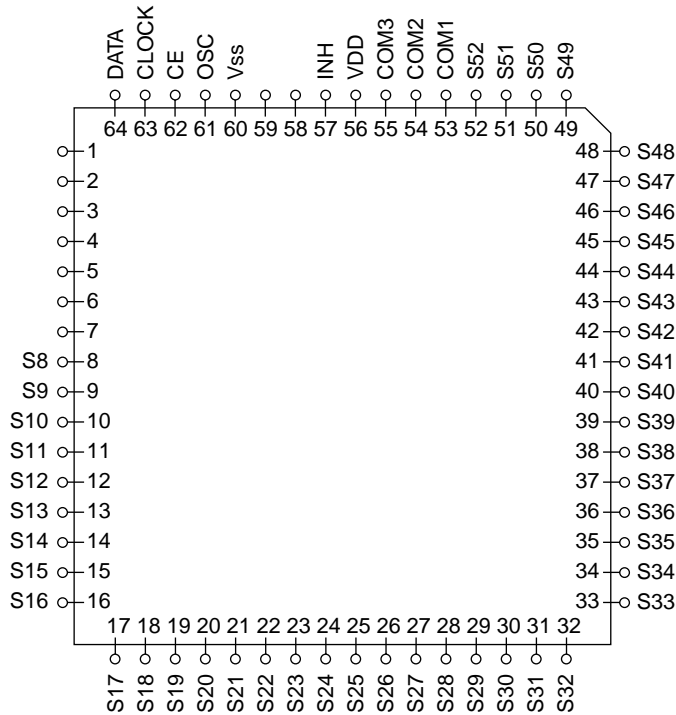

2. Pin Function

Pin No.	Symbol	I/O	Function
1 to 7		--	Non connect
8 to 52	S8 to S52	O	Common driver output pins. The frame frequency is given by : $t_0=(f_{osc}/384)Hz$.
53 to 55	S53 to S55	--	Power supply connection. Provide a voltage of between 4.5 and 6.0V.
57	\overline{INH}	I	Display turning off input pin. $\overline{INT}="L"$ (Vss) ----- off (S1 to S52, COM1 to COM3="L" $\overline{INT}="H"$ (VDD)----- on Serial data can be transferred in display off mode.
58,59			Non connect
60	Vss	--	Power supply connection. Connect to GND.
61	OSC	I/O	Oscillator connection. An oscillator circuit is formed by connecting an external resistor and capacitor at this pin.
62	CE		Serial data interface connection CE : Chip enable
63	CLOCK	I	CL : Sync clock
64	DATA		DI : Transfer data

■ LC72362N-9920 (IC701): System controller

1. Terminal Layout

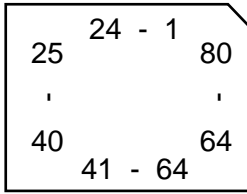

2. Block diagram

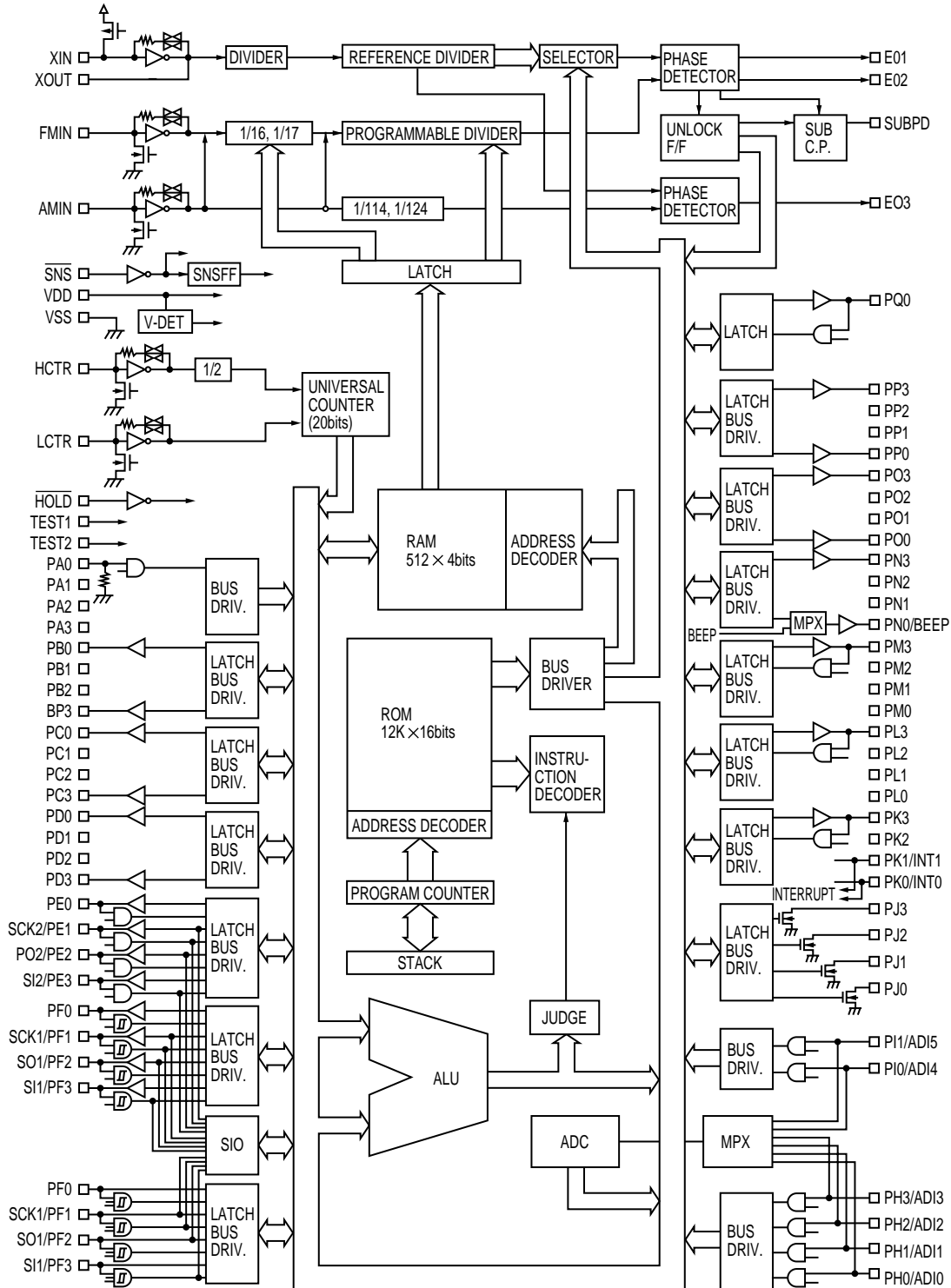

3.Description

LC72362N-9920

Pin No.	Symbol	I/O	Function	Pin No.	Symbol	I/O	Function
1	XIN	I	Crystal oscillator	41	NC	-	Non connect
2	GND	-	To GND	42	NC	-	Non connect
3	J BUS SI	I	Bus serial data input from CP751	43	NC	-	Non connect
4	J BUS SO	O	Bus serial data output to CP751	44	BEEP	-	Non connect
5	J BUS SCK	O	Bus serial clock output to CP751	45	NC	-	Non connect
6	J BUSI/O SEL	O	BUS I/O switch signal output	46	NC	-	Non connect
7	NC	-	Non connect	47	NC	-	Non connect
8	LCD SO	O	Serial data output to IC651	48	TAPE IN	I	H:RADIO L:TAPE
9	LCD SCK	O	Serial clock output to IC651	49	F/R SENSE	I	FORWARD/REVERSE switch detector
10	LCD CE	O	Chip enable output to IC651	50	TAPE MUTE	I	DIR.FF/REW MUTE
11	NC	-	Non connect	51	SD/ST	I	Station detector and ST input
12	E.VOL SO	O	Serial data output	52	NC	-	Non connect
13	E.VOL SCK	O	Serial clock output	53	DETACH	I	Detection of Front Panel
14	NC	-	Non connect	54	NC	-	Non connect
15	TUNER ILLUM	-	Non connect	55	J BUS INT	I	BUS interruption signal detection communication
16	TAPE ILLUM	-	Non connect	56	REMOCON	-	To GND
17	CD ILLUM	-	Non connect	57	FM/AM	I	Change over the FM/AM Input
18	DIMMER OUT	-	Non connect	58	DOLBY	-	Non connect
19	NC	-	Non connect	59	NC	-	Non connect
20	NC	-	Non connect	60	MUTE	-	The mute time is controlled by the connected capacitor when changing over the FM/AM
21	NC	-	Non connect				
22	NC	-	Non connect				
23	NC	-	Non connect				
24	NC	-	Non connect	61	MEMORY DET	I	Memorydetector input
25	KS1	-	Non connect	62	LEVEL METER	I	———
26	KS0	O	Initializing output port	63	SMETER	I	Signal meter input
27	K3	I	Initializing input port	64	KEY 2	I	Mementary key input
28	K2	I	Initializing input port	65	KEY1	I	Mementary key input
29	K1	-	Non connect	66	KEY0	I	Mementary key input
30	K0	I	Initializing input port	67	ACCDET	I	ACC DET
31	Vdd	-	Power supply	68	SENS	-	To GND
32	TEST	I	Test input	69	NC	I	Non connect
33	NC	-	Non connect	70	FM/AM IF COUNT	-	AM/FM Frequency detection
				71	NC	-	Non connect
34	SEEK/STOP	O	Output the "If signal request"	72	NC	-	Non connect
				73	Vdd	I	Power supply
				74	AM OSC	I	Input the local oscillator signal of AM
35	MONO	O	Monaural and stereo change over output	75	FM OSC	-	Input the local oscillator signal of FM
36	RADIO/TAPE	-	Non connect	76	Vss	-	Power supply
37	BEEP LEVEL	-	Non connect	77	NC	O	Non connect
38	POWER CNT	O	Power control output	78	ED	-	PLL Error signal output
39	Acc	-	Power supply	79	TEST 1	O	To GND
40	NC	-	Non connect	80	XOUT		Crystal oscillator

TEA6320T-X (IC931) : E.volume

1.Pin layout

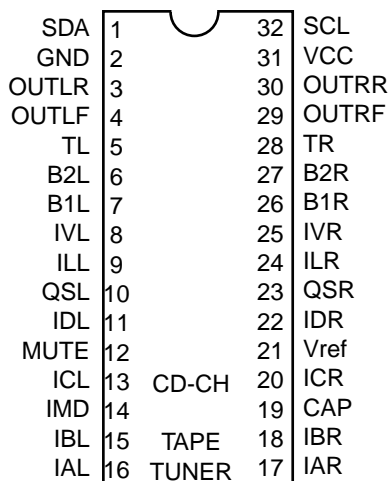

2.Block diagram

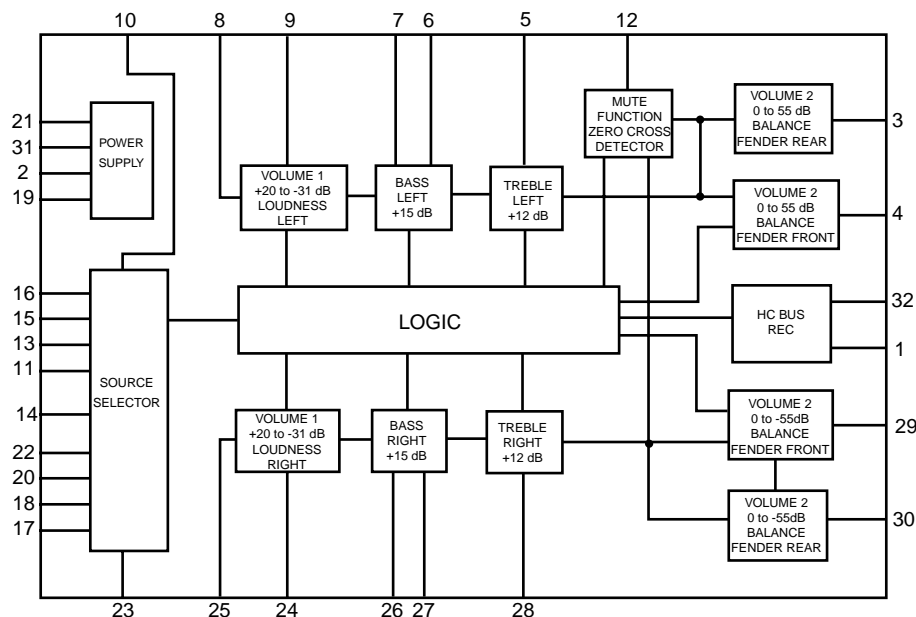

3.Pin functions

Pin No.	Symbol	I/O	Functions	Pin No.	Symbol	I/O	Functions
1	SDA	I/O	Serial data input/output.	17	IAR	I	Input A right source.
2	GND	-	Ground.	18	IBR	I	Input B right source.
3	OUTLR	O	output left rear.	19	CAP	-	Electronic filtering for supply.
4	OUTLF	O	output left front.	20	ICR	I	Input C right source.
5	TL	I	Treble control capacitor left channel or input from an external equalizer.	21	Vref	-	Reference voltage (0.5Vcc)
6	B2L	-	Bass control capacitor left channel or output to an external equalizer.	22	IDR	-	Not used
7	B1L	-	Bass control capacitor left channel.	23	QSR	O	Output source selector right channel.
8	IVL	I	Input volume 1. left control part.	24	ILR	I	Input loudness right channel.
9	ILL	I	Input loudness. left control part.	25	IVR	I	Input volume 1. right control part.
10	QSL	O	Output source selector. left channel.	26	B1R	-	Bass control capacitor right channel
11	IDL	-	Not used	27	B2R	O	Bass control capacitor right channel or output to an external equalizer.
12	MUTE	-	Not used	28	TR	I	Treble control capacitor right channel or input from an external equalizer.
13	ICL	I	Input C left source.	29	OUTRF	O	Output right front.
14	IMO	-	Not used	30	OUTRR	O	Output right rear.
15	IBL	I	Input B left source.	31	Vcc	-	Supply voltage.
16	IAL	I	Input A left source.	32	SCL	I	Serial clock input.

■ HA13158A (IC981) : Power amp

1. Pin layout

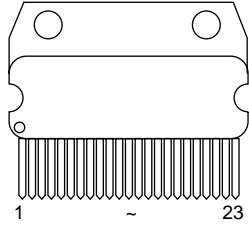

2. Block diagram

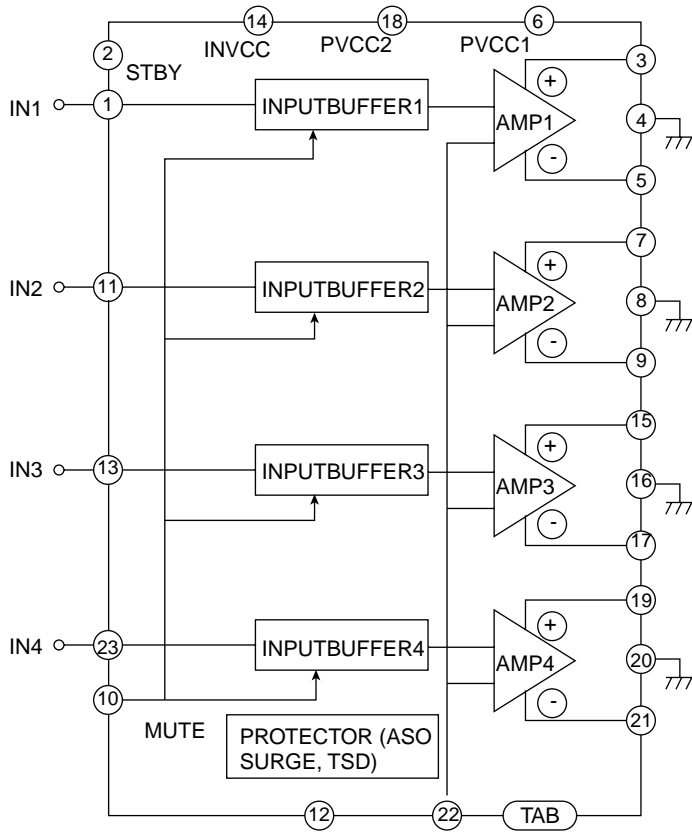

■ UPC1228HA(IC901):Head amp

1. Terminal layout & Block diagram

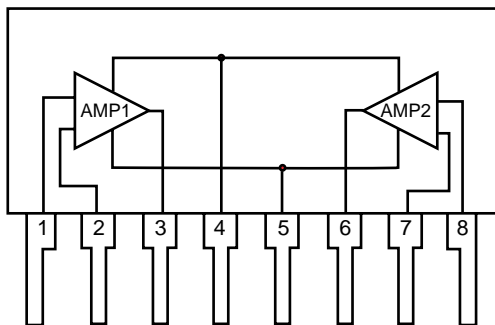

2. Pin function

Pin No.	Electrical connection
1	Input 1
2	Negative feed back 1
3	Output 1
4	Power supply; +Vcc
5	Ground
6	Output 2
7	Negative feed back 2
8	Input 2



VICTOR COMPANY OF JAPAN, LIMITED
MOBILE ELECTRONICS DIVISION
PERSONAL & MOBILE NETWORK BUSINESS UNIT. 10-1,1Chome,Ohwatari-machi,Maebashi-city,Japan